

CEILING MOUNT INSTALLATION

Evolution xR6
SLIM MODEL



NOTE: The total weight of the complete unit is 150 lbs.

COMPONENTS

Carton #1

“S” Arm with Rotational Device
Mounting Post

Carton #2

Mounting Plate
Set Screws
Pin
Set Screw Squarehead
Hex Nut
Ceiling Mount Flange

Installation Procedures For The Seiler Ceiling Mount

To be sure that the unit is properly secured to the structural members of the building, ensure mounting integrity and stability. Such members will usually be located above a dropped ceiling. If it is necessary to span between members in order to mount the unit the installer must insure that whatever material they elect to use (i.e. lumber, angles, channels, etc.) possesses the strength and rigidity required to provide stability.

Unpack all of the boxes and verify that all of the parts are present, noting that some are in a sub-assembly state. Any loose pieces will be labeled with their corresponding part number.



Using the template provided, transfer the hole locations onto the structural members to which the unit will be mounted. It is recommended that the unit be thru-bolted into the member using 1/2" bolts and nuts. In some applications, when thru-bolting is not possible, it may be necessary to use lag bolts or some other type of anchoring.

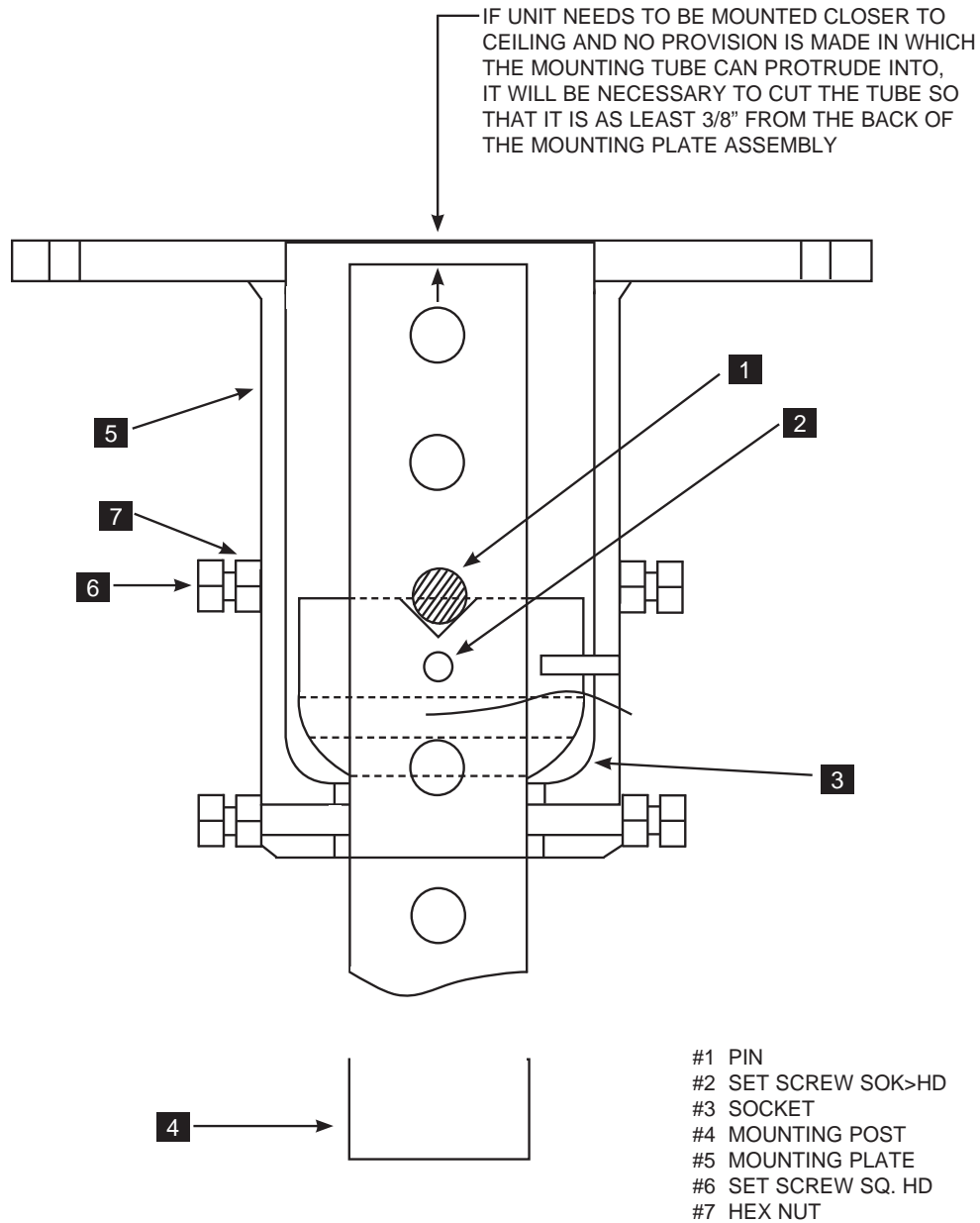

The unit can be installed at a nominal height with plus/minus adjustment of four inches available in two inch increments. The center hole of the five Pin locating holes in the Mounting Post is the nominal height. If the unit must be mounted closer to the ceiling than the nominal height, it will be necessary for the installer to provide either a four inch diameter opening above the Mounting Plate Assembly for the Mounting Post to protrude into, or cut off any of the Mounting Post material that comes to within 3/8 inch of the back of the Mounting Plate Assembly. This provides the clearance that is necessary to allow for any tilt adjustment.



Place the Mounting Plate Assembly **5** on its side to allow parts to be placed into it from both the top and bottom. Back out all Square Head Set Screw **6** in order to insert column **4**. Feed in Mounting Post **4** through the opening of Mounting Plate with the end of the Mounting Post that has the **5** pin mounting holes entering first. Push the Mounting Post through far enough to allow the Socket **3** to be installed onto the Mounting Post in such a position that the Pin **1** can be installed in the proper holes above the Socket. Then slide the Socket back up so that the Pin engages in the “V” groove in the Socket and ensure that the Pin protrudes the same amount from each side of the Post. While holding the Socket firmly against the Pin, tighten the Set Screw **2** (1/8” hex key) in the Socket to lock it to the Post. Then pull the Mounting Post back through the Mounting Plate Assembly and hand tighten the six Set Screws **6** to hold the Post/Socket Assembly in place while attaching the complete unit to the ceiling structure (Note: loosen the Hex Nuts **7** to allow movement of the Set Screws **6**). Have an assistant lift the Post Assembly into position and fasten the assembly into the structural member. If there is any rocking motion due to a non-flat mounting surface, it will be necessary to shim between the surface and the Assembly to ensure that there is a solid coupling between the two.

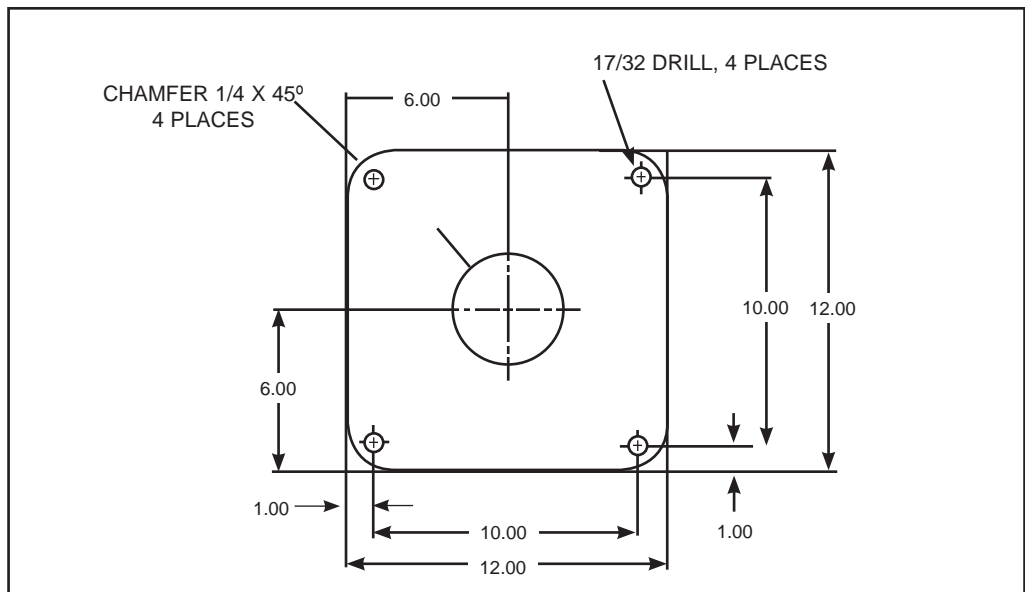
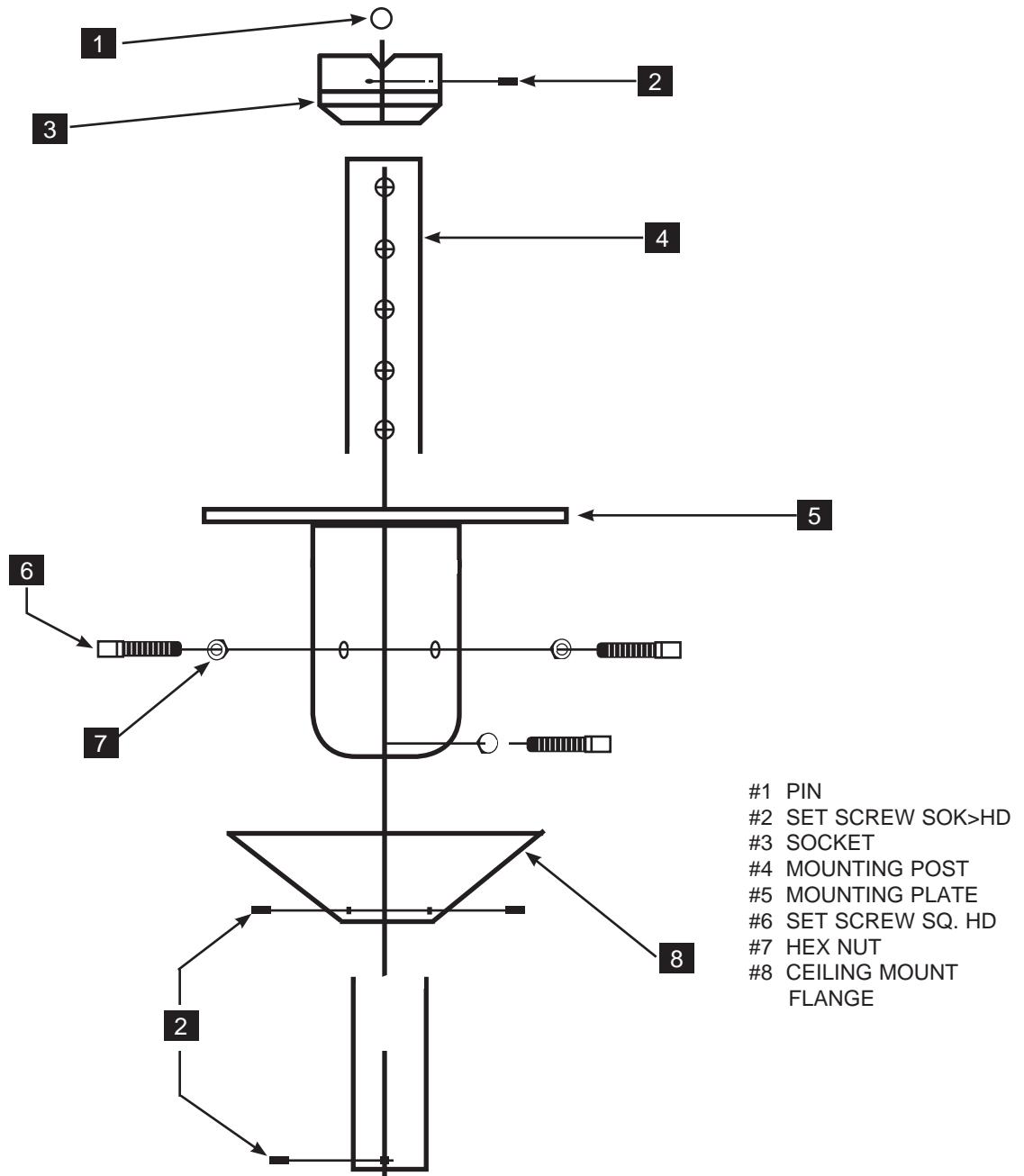

The next step is to level and secure the Mounting Post **4**. To do this, loosen the six Set Screws **6** to allow the Mounting Post to tilt (it has a five degree tilt angle in all directions). Using a carpenter's level held against the Mounting Post and the Mounting Post is plumb position, continue to tighten the set screws assuring that the column remains plumb. The six Nuts **7** may then be tightened against the Mounting Plate Assembly Tube.

In this next step, install the Ceiling Flange Assembly **9** over the Mounting Post with the flat side towards the ceiling. Slide it up the Post approximately two feet and lightly tighten the three Set Screws **2** to hold the Flange Assembly in this temporary position. Thread the Shaft **12** into the Mounting Post **4** until it stops against the shoulder of the Shaft and then insert the Set Screw **2** into the Mounting Post and tighten it (1/8" hex key) to lock the Shaft into place.

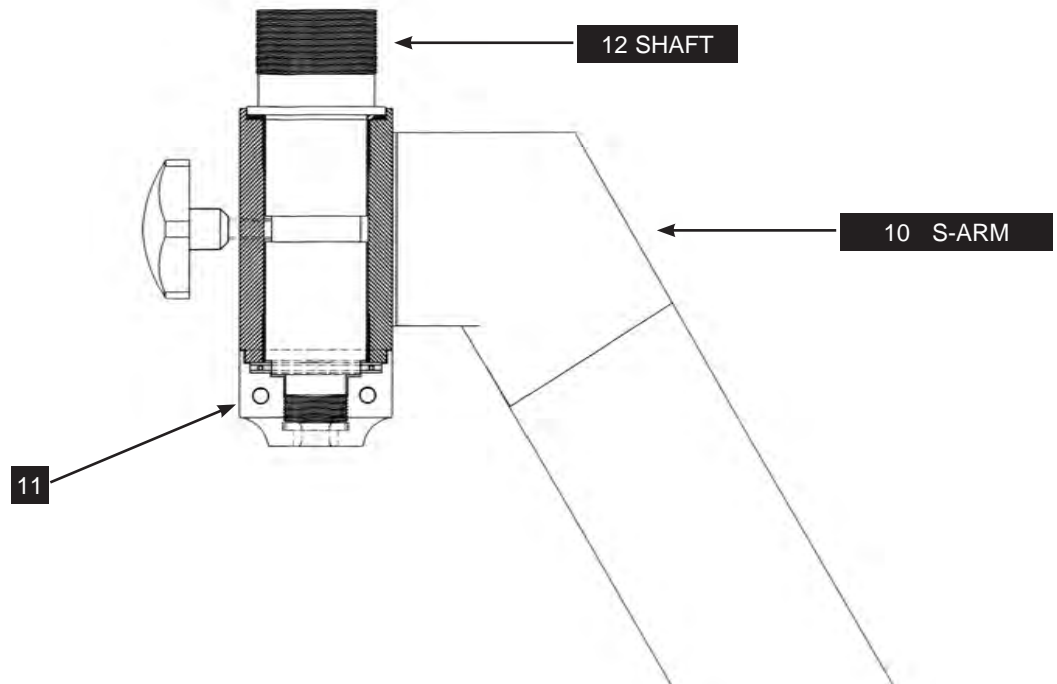

Positioning

High Wall and Ceiling Recommended Mounting Location

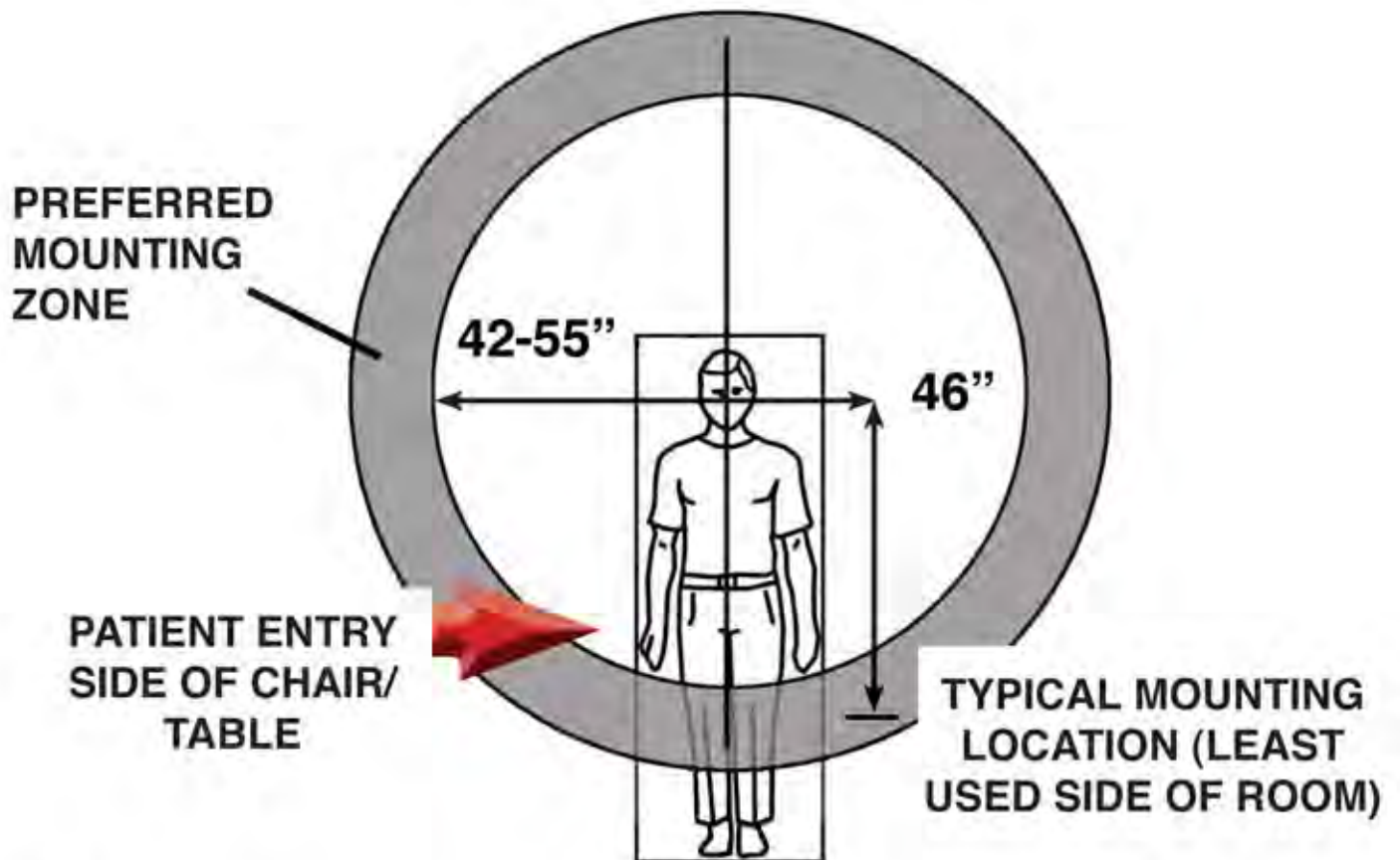

NOTE:

If the typical position is not available, locating the microscope within the Preferred Mounting Zone (vertically shaded) will ensure that there is maximum maneuverability of the microscope in all directions. Locating the microscope within the Secondary Mounting Zone (diagonally shaded) is possible, depending

Right Handed

WALL MOUNT

Left Handed

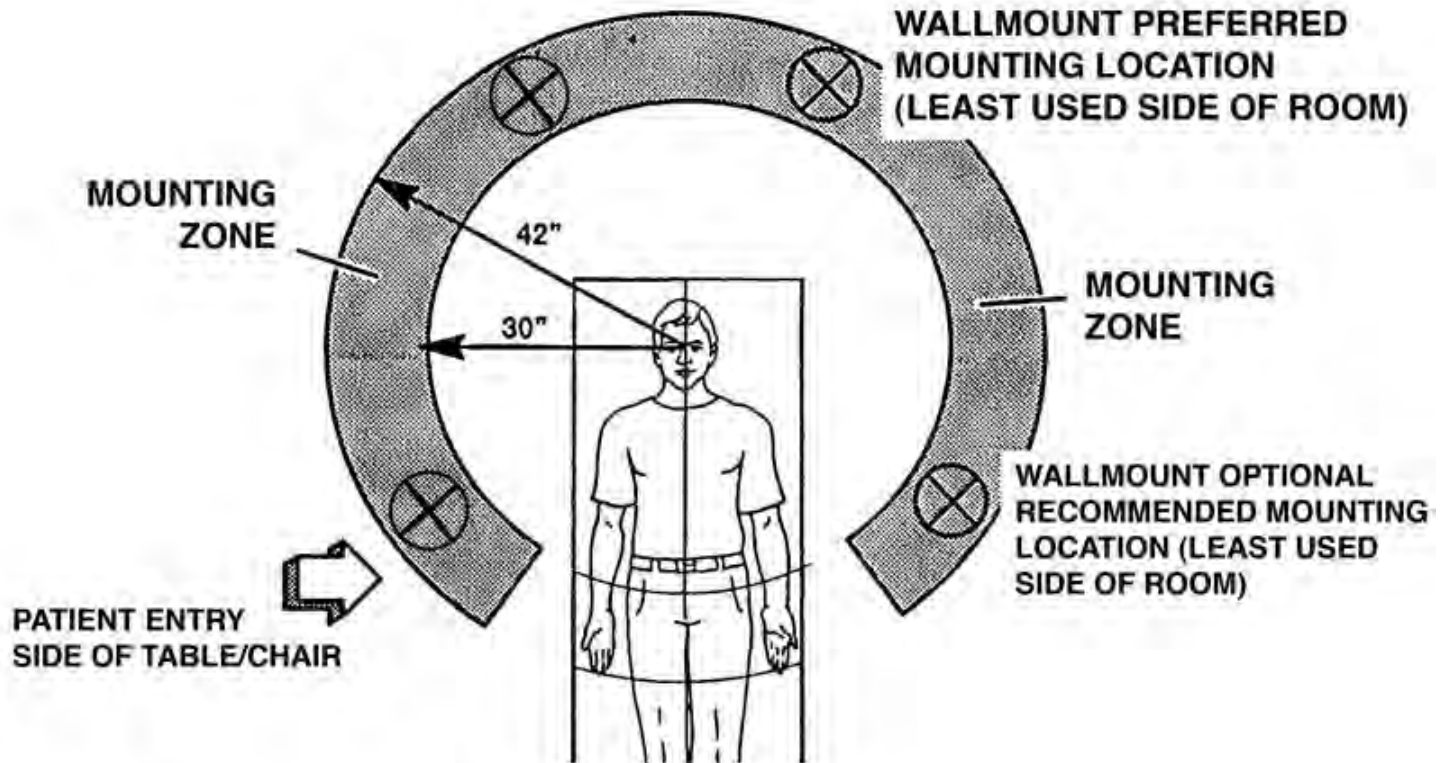

NOTE:

If either of the two recommended locations is not available, locating the wall mount within the shaded mounting zone will ensure that there is maximum maneuverability of the microscope in all directions.

Right handed dentists typically should mount the microscope on their right side. This allows for better four-handed dentistry with their assistant. The same theory applies to left hand dentists.

Note: Turning the cap **11** clockwise or counter-clockwise will adjust Rotation Tension. All holes contain a Set Screw which locks the desired tension. Tighten Set Screw **2** to secure. Prior to shipping, the set screw was tightened arbitrarily in order to allow previously mentioned assembly procedure.

After the entire microscope is assembled to the Ceiling Mount, check for satisfactory rotational movement.

Optional: Cut off male plug from cord and feed up through cap **11** until into ceiling space and install connector

A thru hole is provided to wire the Assembly into the ceiling. Check with the electrical code on how to wire for the ceiling outlet.



NOTE: These instructions are based on a standard installation, for other height dimensions, please consult with the Technical Department at Seiler Precision Microscopes.

Evolution xR6 Slim Ceiling Mount

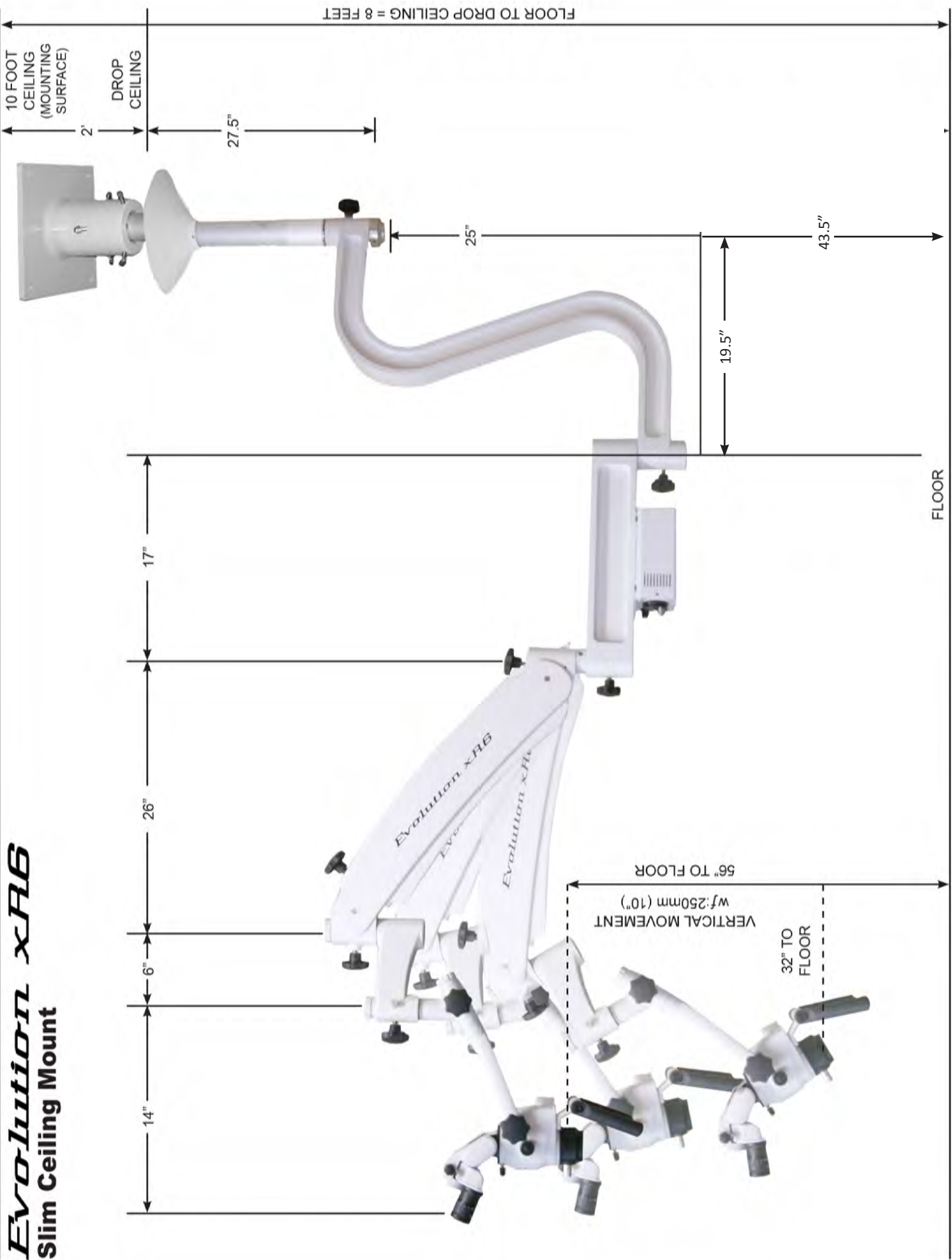

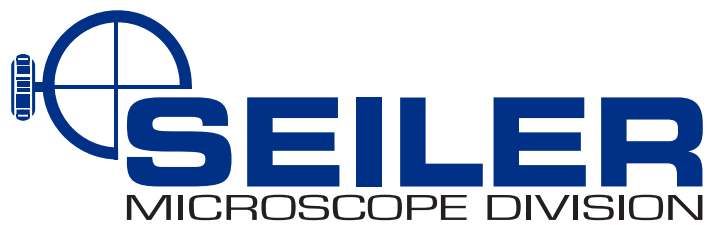

TO CONTACT SEILER PRECISION MICROSCOPES

By Mail:

3433 Tree Court Industrial Blvd. • St. Louis, MO 63122

By Phone:

(314) 968-2282 • (800) 489-2282 toll-free • (314) 968-3601 fax

By E-mail:

micro@seilerinst.com

www.seilerinst.com