

Wall Mounted Model Installation Instructions

SEILER IQ





- 1) Determine suitable location: Wall next to doctor, wall behind doctor, etc. at a distance no greater than 60" and no less than 36" from the wall to the patients mouth.
- 2) Position the wall bracket with the threaded opening facing down and with the lower mounting holes 45" above the floor. Fasten the wall bracket to the wall making sure the wall construction is wood stud (16" on center) or cinder block. All other constructions require wall bracing - contact your building maintenance department or an outside contractor in this case.

After the wall bracket is securely attached to the wall, carefully thread the bearing and microscope holder assembly into the bottom opening of the bracket until it is hand tight.



The wall mount assembly is now ready to receive the iQ power supply housing.



Please see diagram on following page for additional information on set-up configuration.

SEILER ID

Wall Mount

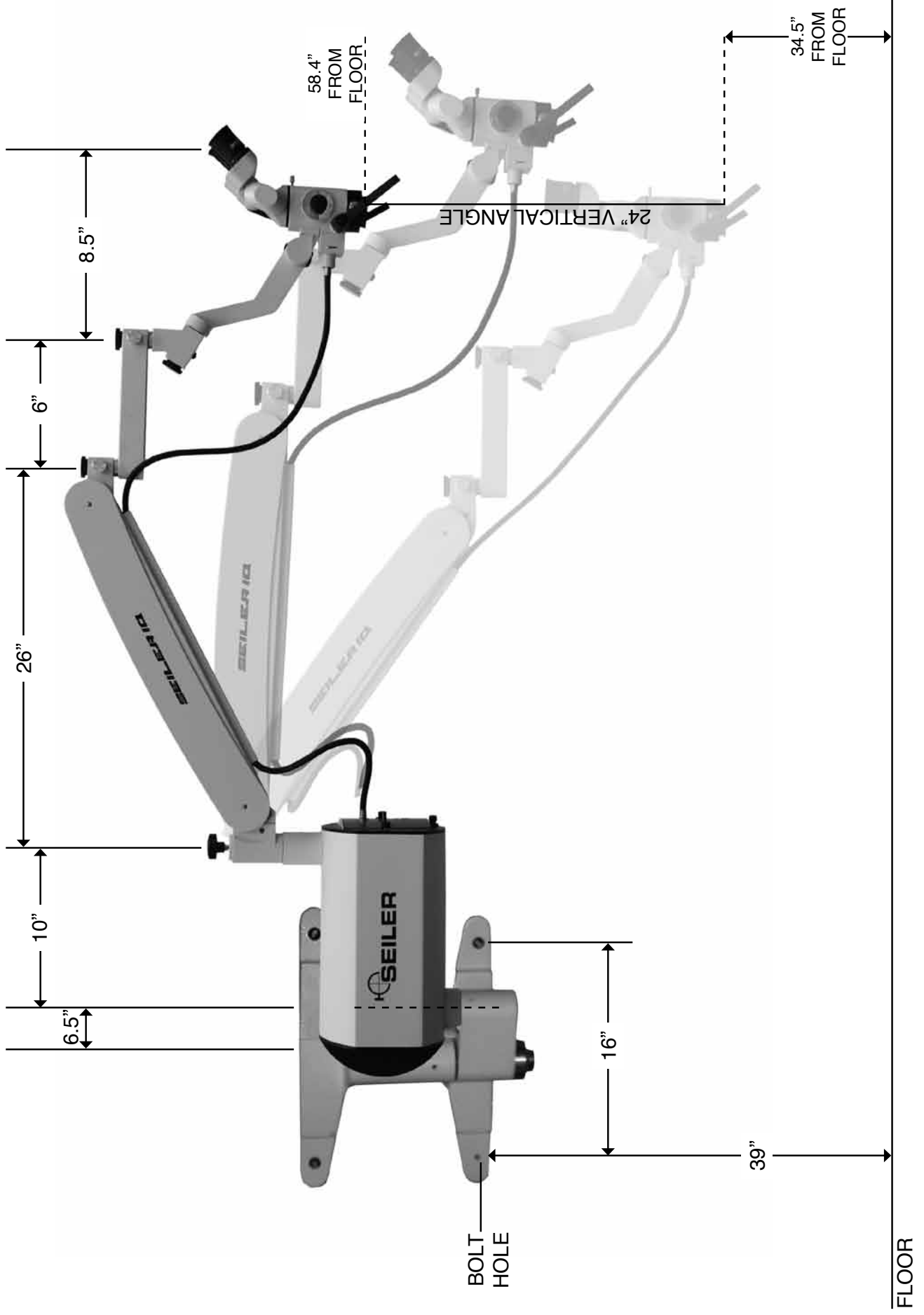

Positioning

High Wall and Ceiling Recommended Mounting Location

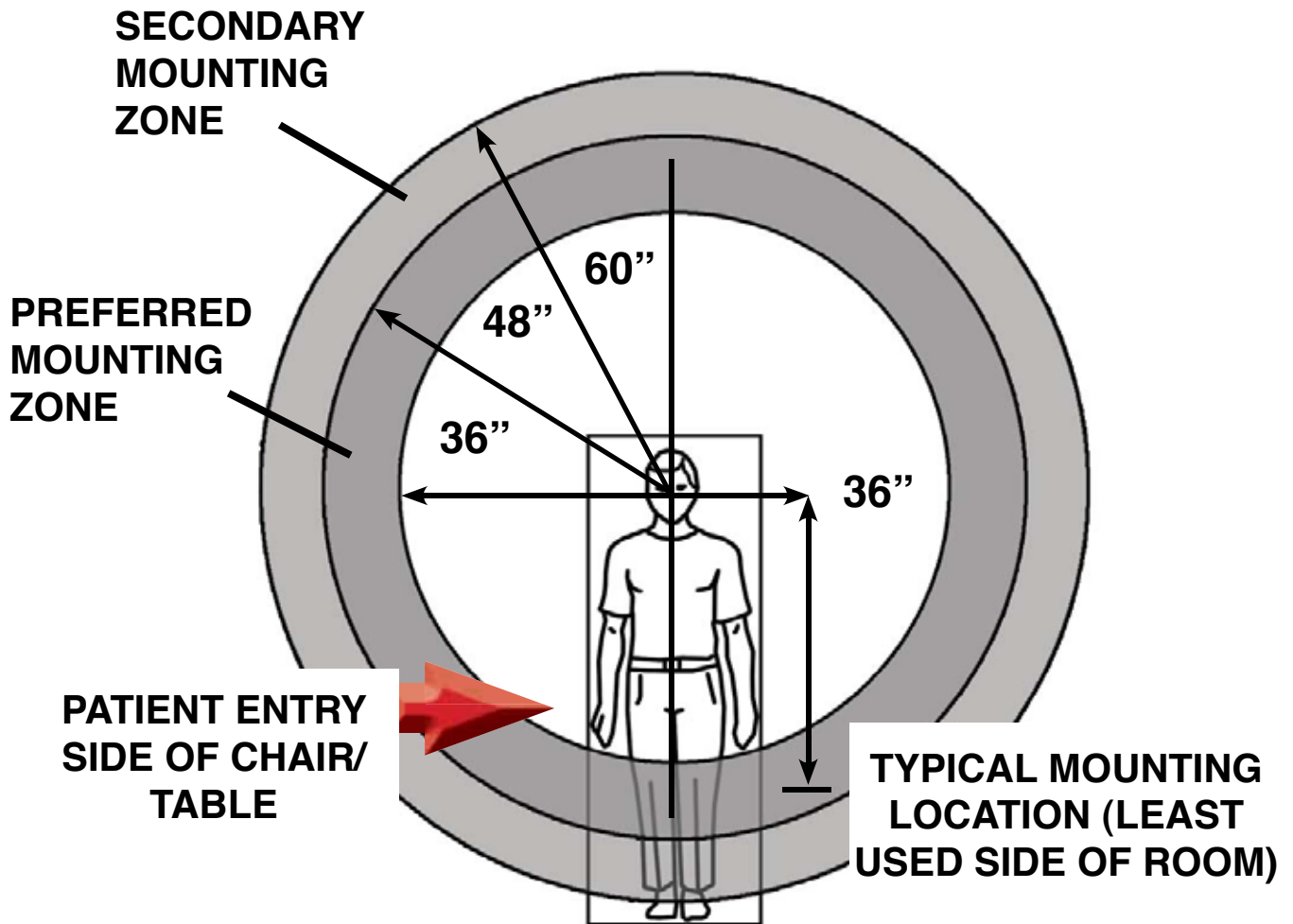

NOTE:

If the typical position is not available, locating the microscope within the Preferred Mounting Zone (vertically shaded) will ensure that there is maximum maneuverability of the microscope in all directions. Locating the microscope within the Secondary Mounting Zone (diagonally shaded) is possible, depending upon the specific layout of a room, but may reduce maneuverability.

Right Handed

WALL MOUNT

Left Handed

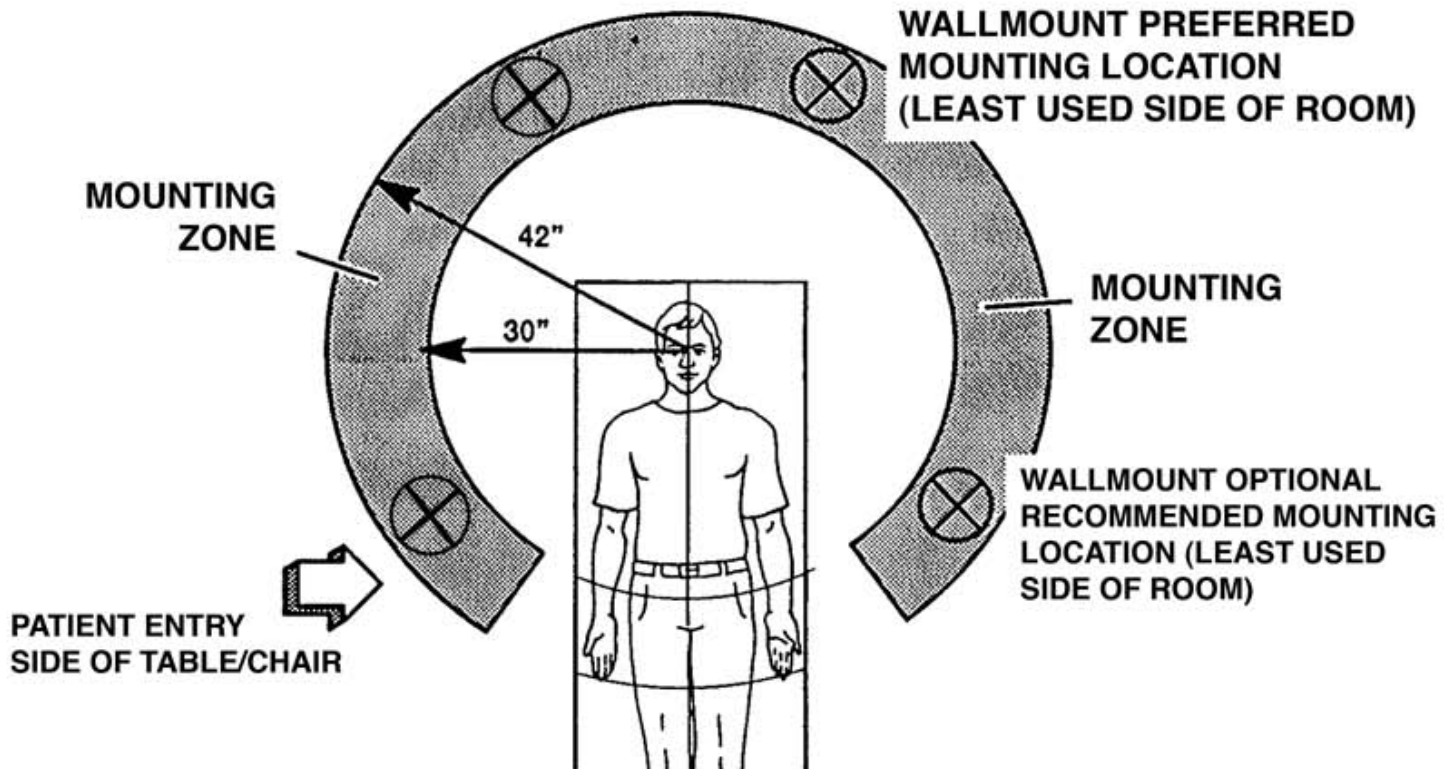

NOTE:

If either of the two recommended locations is not available, locating the wall mount within the shaded mounting zone will ensure that there is maximum maneuverability of the microscope in all directions.

Right handed dentists typically should mount the microscope on their right side. This allows for better four-handed dentistry with their assistant. The same theory applies to left hand dentists.

Seiler Precision Microscopes does not supply screws for mounting wall brackets. The type of screws and/or anchors to be used should be determined by a qualified contractor. If mounting to a metal studded wall, there needs to be backing such as plywood mounted to each side of the wall and the screws to attach the wall bracket to through both pieces of plywood, the entire thickness of the wall so it is structurally sound.

For mounting to a wood studded wall, large Lag screws should be sufficient. Again, a professional contractor should determine size and length.

Wedge Anchors

Wedge anchors are for attaching fixtures to a solid such as concrete. The installed end of the anchor features a conical segment with a metal clip around it. Upon setting the anchor the cone pulls up through the clip and pushes the clip against the sides of the hole. This gives the anchor its holding power within the hole. Anchor diameter will be equal to the hole size.

Expansion of the wedge anchor creates large point bearing stresses within the hole; therefore, this anchor requires a solid base material to develop its full capacity. For this reason, brick and partially filled mortar joints in brick walls or paving may be unsuitable for wedge anchor usage.

Sleeve Anchors

Sleeve anchors also are used to attach fixtures to solid materials. A bolt is surrounded by a cylindrical metal sleeve. They operate by the expansion of the sleeve into the base material when one tightens the bolt. Expanding the sleeve along the length of the anchor enables a larger bearing surface than that offered by the wedge anchor, and can better adhere to irregular surfaces within the base material than can the wedge anchor. Therefore, sleeve anchors can be better suited for brick masonry than wedge anchors. Sleeve anchor diameter will be equal to the hole size.

Sleeve Anchors come in models with round-headed bolts, flat-headed bolts, bolts with a hex nut/washer assembly, and bolts with an acorn nut/washer assembly.

Drop-In Anchors

Drop-In Anchors are designed for solid concrete base material, and are not recommended for masonry or brick. Drop-in anchors are a female mating part anchor with coarse threads. The drop-in anchor requires a setting tool for expanding the anchor.



Expansion Shield (Single Expansion Shield or Double Expansion Shield)

Expansion shields may be single or double piece design. Both are inserted for shear loads or where the bolt may be under side pressure or vibration. Expansion shields consist of a nut, a cone and a tubular shield that are put together as a single unit. The two-piece tubular shield in either version contains a wedge shaped nut at one end, a wedge shaped hollow cone at the other end and is held in place by two spring bands. The expansion at both ends of the shield spreads the anchored load throughout its length.

Personnel

We are here to serve you!

If you have any questions regarding Seiler's products or services, please feel free to contact us.

-  : 800.489.2282
-  : 314.968.2282
-  : 314.968.3601
-  : micro@seilerinst.com
-  : www.seilerinst.com

- Division Manager
Dane Carlson
ext. 365 • dcarlson@seilerinst.com
- Corporate Accounts/Marketing
Nicholas Toal
ext. 345 • ntoal@seilerinst.com
- Technical Product Information
Tony Leise
ext. 363 • tleise@seilerinst.com
- Literature
Beverly Brown
ext. 322 • bbrown@seilerinst.com
- Accounts/Tracking/Bulbs
Sandy Jeremich
ext. 336 • sjeremich@seilerinst.com

